

**Square and Rectangular Ceiling Diffusers
Steel • Louvered Face • High Capacity**

Model: TDC • Square, Rectangle or Round Neck

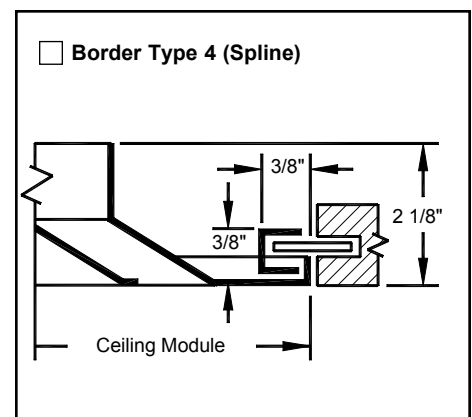
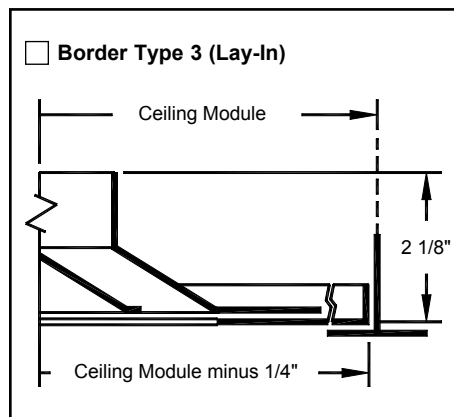
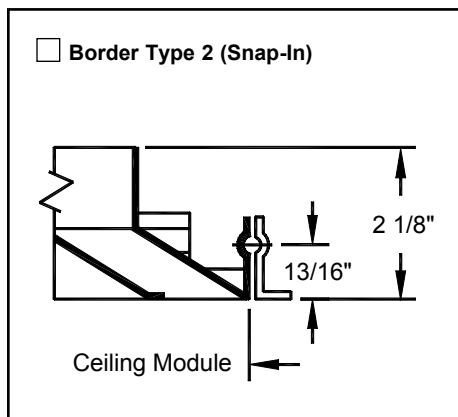
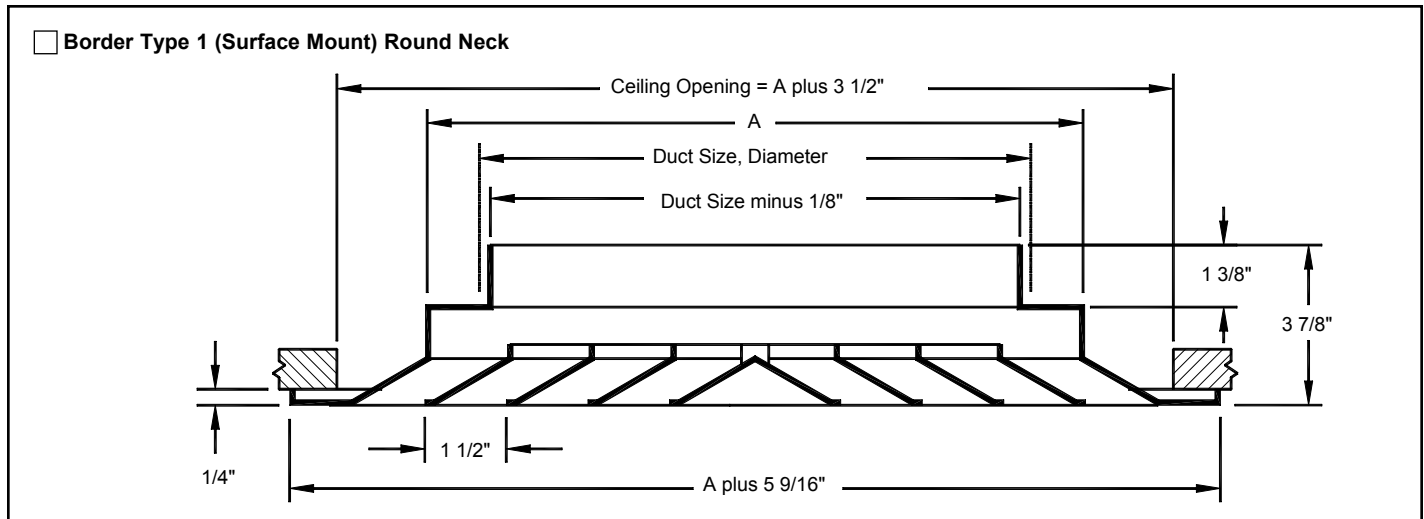
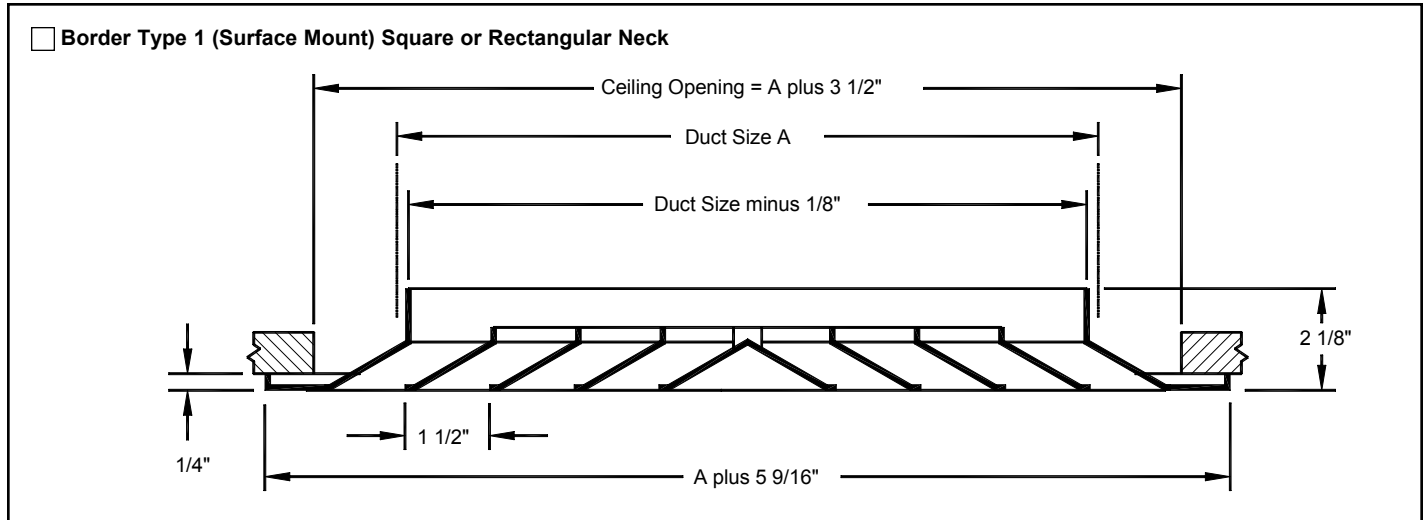

For Dimensions "A" see table on next page.

Dimensions are in inches.

Border Types, Dimensions (Continued)

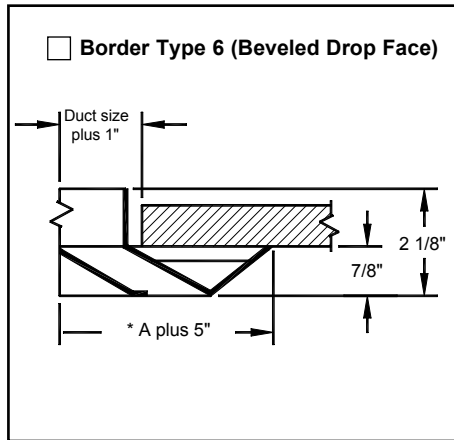
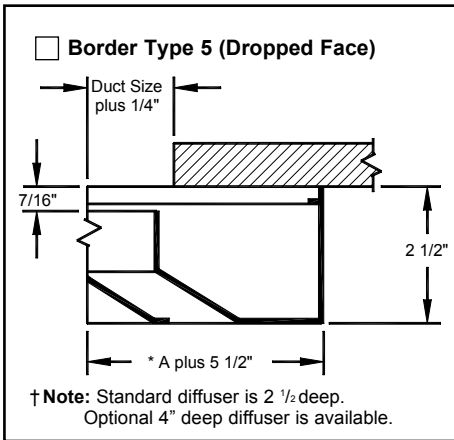

***Note:** Dimension A refers to either square/rectangle or round neck diffusers. See drawings below.

Available Duct Sizes, Square and Rectangular Necks

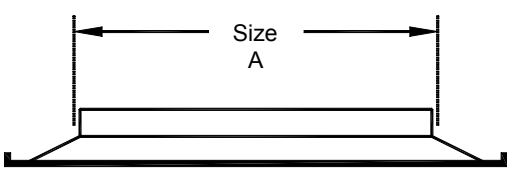

Border Type 1, 5, 6	
Minimum Duct Size A	Maximum Duct Size A
6 x 6	48 x 48

Border Type 2, 3, 4		
Available Module Size	Minimum Duct Size A	Maximum Duct Size A
12 x 12	6 x 6	9 x 9
24 x 24	6 x 6	21 x 21
48 x 24	12 x 12	45 x 21

Note: Duct sizes are available in 3" increments only.
Maximum duct size for border 5 is 36 x 36.

Available Duct Sizes, Round Necks

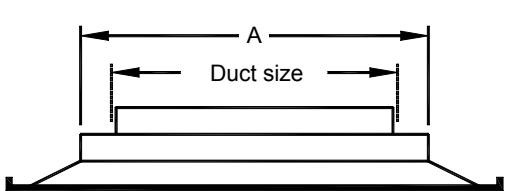

Border Type 1, 5, 6	
Dimensions A	Available Round Duct Size
6 x 6	6
9 x 9	6, 8
12 x 12	8, 10, 12
15 x 15	6, 8, 10, 12, 14
18 x 18	6, 8, 10, 12, 14, 16

Border Type 2,3,4		
Available Module Size	Minimum A	Available Rnd. Duct Size
12 x 12	6 x 6	6
	9 x 9	6, 8
24 x 24	6 x 6	6
	9 x 9	6, 8
	12 x 12	8, 10, 12
	15 x 15	12, 14
	18 x 18	6, 8, 10, 12, 14, 16

***Note:** Round duct sizes are available only in sizes shown.

Accessories (Optional) for Round Neck

Check if provided

Model AG-100 Radial Sliding Blade Damper *

Model EG Equalizing Grid

1 Model AG-100 damper is available in duct sizes 6 thru 14 inches only

Model D-100 Radial Sliding Blade Damper *

Model EG Equalizing Grid

2 Model D-100 damper is available in duct sizes 6 thru 14 inches only.

Model D-75 Opposed Blade Damper *

Model EG Equalizing Grid

3 Model D-75 damper is available in duct sizes 6 thru 12 inches only

Model AG-85 Butterfly Damper *

Model EG Equalizing Grid

4

Model AG-65 Combination Damper and Equalizing Grid *

5

Model AG-75 Opposed Blade Damper *

Model EG Equalizing Grid

Size	B
6-12	1 1/2
14-16	2 1/8

6

Dimension "A" in Inches, for Dampers Shown as Above

Accessories	Nominal Round Duct Sizes					
	6	8	10	12	14	16
1 AG-100	—	—	—	—	—	N/A
2 D-100	—	—	—	—	—	N/A
3 D-75	2 3/8	3 1/4	4 1/8	4 7/8	N/A	N/A
4 AG-85	2 1/2	3 1/2	4 1/2	5 1/2	6 1/2	7 1/2
5 AG-65	3 3/8	4 1/2	5 1/2	7 1/8	8 5/8	9 7/8
6 AG-75	4 1/4	5 1/8	6	6 7/8	2 3/4	3 1/2

Notes 1 and 2 :

Model AG-100 and D-100 dampers have radial blades that slide in a horizontal plane. For that reason, no opening clearance "A" is dimensioned.

*Damper operators on all round neck dampers are screwdriver type. Remove diffuser core (See back page) for access.

Submittal D-TDC 11-11-02
Accessories (Optional) for Rectangular Neck

Check if provided

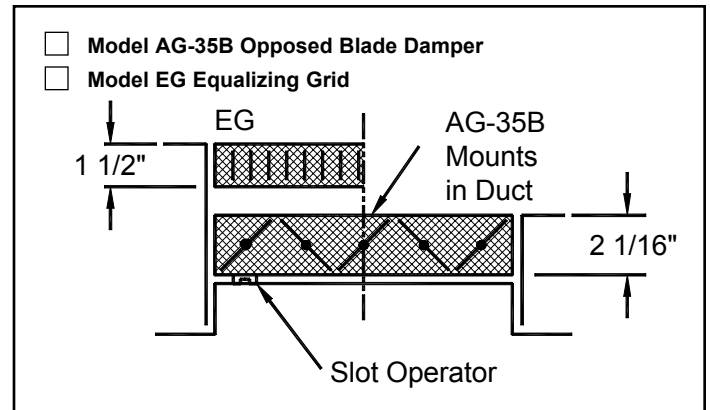
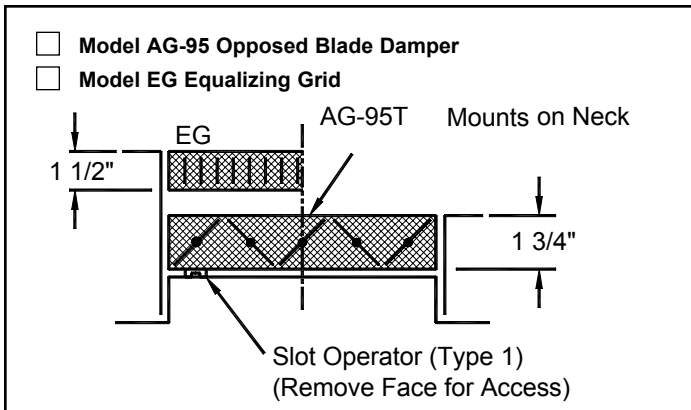

All dimensions are in inches.

Other Accessories (Optional)

Standard Finish: #26 White

- Model TRV Throw Reducing Vanes
 Model SR Square-to-Round Transition

Optional Patterns

Check selection

1 Way	<input type="checkbox"/> S1 Square	<input type="checkbox"/> A1	<input type="checkbox"/> B1
2 Way	<input type="checkbox"/> A2	<input type="checkbox"/> S2 Square	<input type="checkbox"/> B2
2 Way Corner	<input type="checkbox"/> E2	<input type="checkbox"/> F2	<input type="checkbox"/> G2 Square
3 Way	<input type="checkbox"/> A3 $X \geq Y$	<input type="checkbox"/> E3 $X > 2Y$	* Dimensions X and Y shown here are the proportions of available rectangular duct sizes. Duct sizes are available in 3" increments. Dimension X is always the longer dimension for each core option.
	<input type="checkbox"/> A3-2 $X > Y, X < 2Y$	<input type="checkbox"/> B3 $X = 2Y$	
4 Way	<input type="checkbox"/> A4 Square	<input type="checkbox"/> B4	

Removing Center Core

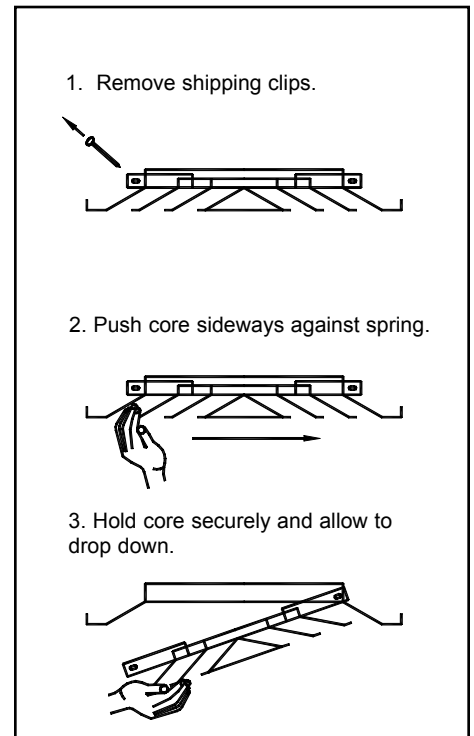

General Description

- TITUS Model TDC is a high capacity ceiling diffuser. Because it maintains an unbroken horizontal flow pattern from maximum cfm down to minimum, it is an excellent choice for variable air volume application.
- Core is removable from the face of the diffuser.
- Model TDC is extremely flexible, with cores available for 1, 2, 3 or 4-way horizontal flow patterns.
- Lever operator on optional Model AG-95 damper allows easy volume adjustment from the face of the diffuser. (Rectangular necks only).
- Material is heavy gauge steel.



Note: This submittal is meant to demonstrate general dimensions of this product. The drawing on this submittal are not meant to detail every aspect of the product with exactness. Drawings are not to scale. TITUS reserves the right to make changes without written notice.

D-38.0-S